

MOD:XEBC-10EU-GPRM



ENGLISH

TECHNICAL DATA

01 POWER	1,4 kW
03 FREQUENCY	50 / 60 Hz
04 POWER SUPPLY CABLE TYPE	H07RN-F
05 EXTERNAL Ø OF POWER SUPPLY CABLE	12 mm
06 VOLTAGE / POWER CABLE SECTION / CURRENT	220-240 V~1PH+N+PE 3G x 1,5 mm ² Circuit Breaker 10 A I1=6 A
10 WATER PRESSURE	150-600 kPa / 21-87 kPa
11 MAX FOOD LOAD	50 kg
13 WATER MAX CONSUMPTION	10,3 l/h @ 200 kPa
16 GAS NOMINAL HEAT INPUT	25 kW
17 TOTAL NOMINAL HEAT INPUT	25 kW
18 CAVITY DIMENSIONS (W - D - H)	716x561x880 mm
20 IP PROTECTION CLASS	X4

ITALIANO

01 POTENZA	1,4 kW
03 FREQUENZA	50 / 60 Hz
04 TIPO DI CAVO ALIMENTAZIONE	H07RN-F
05 Ø ESTERNO CAVO DI ALIMENTAZIONE	12 mm
06 TENSIONE / SEZIONE CAVI ALIMENTAZIONE / CORRENTE	220-240 V~1PH+N+PE 3G x 1,5 mm ² Circuit Breaker 10 A I1=6 A
10 PRESSIONE ACQUA	150-600 kPa / 21-87 kPa
11 CARICA MAX CIBO	50 kg
13 CONSUMO MAX ACQUA	10,3 l/h @ 200 kPa
16 POTENZA TERMICA NOMINALE GAS	25 kW
17 POTENZA TERMICA NOMINALE TOTALE	25 kW
18 DIMENSIONI CAMERA COTTURA (L - P - H)	716x561x880 mm
20 GRADO PROTEZIONE IP	X4

FRANCAIS

01 PUISSANCE ELECTRIQUE	1,4 kW
03 FREQUENCE	50 / 60 Hz
04 TYPE DE CABLE D'ALIMENTATION	H07RN-F
05 Ø EXTERNE DU CABLE D'ALIMENTATION	12 mm
06 TENSION / SECTION CABLE D'ALIM.	220-240 V~1PH+N+PE 3G x 1,5 mm ² Circuit Breaker 10 A I1=6 A
10 PRESSION DE L'EAU	150-600 kPa / 21-87 kPa
11 CHARGE MAXIMALE D'ALIMENT	50 kg
13 CONSOMMATION MAX DE L'EAU	10,3 l/h @ 200 kPa
16 PUISSANCE THERMIQUE NOMINAL GAZ	25 kW
17 TOTAL DEBIT THERMIQUE NOMINAL	25 kW
18 DIMENSIONS CHAMBRE DE CUISSON (L - P - A)	716x561x880 mm
20 INDICE DE PROTECTION IP	X4

ESPAÑOL

01 POTENCIA	1,4 kW
03 FRECUENCIA	50 / 60 Hz
04 TIPO DE CABLE DE ALIMENTACION	H07RN-F
05 Ø CABLE EXTERNO DE ALIMENTACION	12 mm
06 TENSION / SECCION CABLES DE ALIMENTACION	220-240 V~1PH+N+PE 3G x 1,5 mm ² Circuit Breaker 10 A I1=6 A
10 PRESION AGUA	150-600 kPa / 21-87 kPa
11 CARGA MAX. DE ALIMENTOS	50 kg
13 CONSUMO MAX DE AGUA	10,3 l/h @ 200 kPa
16 POTENCIA TÉRMICA NOMINAL GAS	25 kW
17 TOTALE POTENCIA TERMICA NOMINAL	25 kW
18 DIMENSIONES CÁMARA DE COCCIÓN (An - Pr - Al)	716x561x880 mm
20 GRADO DE PROTECCION IP	X4

DEUTSCH

01 ELEKTRISCHE LEISTUNG	1,4 kW
03 FREQUENZ	50 / 60 Hz
04 ZULEITUNGSKABELTYP	H07RN-F
05 AUSSENDURCHMESSER DES VERSORGUNGSKABELS	12 mm
06 KABELQUERSCHNITT UND VERSORGUNGSSPANNUNG	220-240 V~1PH+N+PE 3G x 1,5 mm ² Circuit Breaker 10 A I1=6 A
10 WASSERDRUCK	150-600 kPa / 21-87 kPa
11 MAX. SPEISENFASSUNGSVERMOGEN	50 kg
13 MAXIMUM WASSERVERBRAUCH	10,3 l/h @ 200 kPa
16 GAS NENNWÄRMELEISTUNG	25 kW
17 NENNWÄRMEBELASTUNG	25 kW
18 GRÖÖE DES KOCHKAMMERS (B - T - H)	716x561x880 mm
20 SCHTZART IP	X4



MOD:XEBC-10EU-GPRM



ENGLISH - DRAWINGS

2	TERMINAL BOARD POWER SUPPLY
3	UNIPOTENTIAL TERMINAL
6	TECHNICAL DATA PLATE
7	SAFETY THERMOSTAT
8	3/4" THREAD WATER INLET
9	3/4" GAS INLET
10	Rotor.KLEAN CONNECTION
11	CAVITY DRAIN PIPE
12	HOT FUMES EXHAUST CHIMNEY
13	ACCESSORIES CONNECTION
27	COOLING AIR OUTLET
30	COMBUSTION GASSES EXHAUST

ITALIANO - DISEGNI

2	MORSETTIERA ALIMENTAZIONE
3	MORSETTO EQUIPOTENZIALE
6	TARGHETTA DATI TECNICI
7	TERMOSTATO DI SICUREZZA
8	INGRESSO ACQUA 3/4"
9	INGRESSO GAS 3/4"
10	INGRESSO Rotor.KLEAN
11	SCARICO CAMERA DI COTTURA
12	USCITA FUMI CALDI
13	COLLEGAMENTO ACCESSORI
27	USCITA ARIA DI RAFFREDDAMENTO
30	USCITA FUMI COMBUSTI

FRANCAIS - ENCOMBREMEN

2	BOITE A BORNES D'ALIMENTATION
3	SUPPORT BORNE EQUIPOTENTIELLE
6	PLAQUETTE SIGNALÉTIQUE
7	THERMOSTAT DE SÉCURITÉ
8	ARRIVÉ D'EAU FIÉLT 3/4"
9	ARRIVÉ DU GAS 3/4"
10	ENTRÉE Rotor.KLEAN
11	SORTIE DE L'EAU RACCORD
12	SORTIE DES FUMÉES CHAUDES
13	JONCTION DES ACCESSOIRES
27	SORTIE D'EAU DE REFOIDISSEMENT
30	SORTIE DES FUMÉES DE COMBUSTION

ESPAÑOL - DISEÑOS

2	CAJA DE CONEXION
3	SEDE BORNE EQUIPOTENCIAL
6	TARJETA DE CARACTERISTICAS TECNICAS
7	TERMOSTATO DE SEGURIDAD
8	ENTRADA DE AGUA 3/4"
9	ENTRADA DE GAS 3/4"
10	INGRESO Rotor.KLEAN
11	DESCARGA CAMARA DE COCCION
12	SALIDA HUMOS CALIENTES
13	CONEXION ACCESORIOS
27	SALIDA DEL AIRE DE ENFRIAMIENTO
30	SALIDA HUMOS DE COMBUSTIÓN

DEUTSCH - ZEICHNUNGEN

2	ZULEITUNGSKLEMMLEISTE
3	GLEICHPOTENTIELLE KLAMMER
6	TYPENSCHILD
7	SICHERHEITSTHERMOSTAT
8	WASSEREINZUG 3/4" GEWINDE
9	GAS EINZUG 3/4" GEWINDE
10	Rotor.KLEAN EINGANG
11	WASSERAUSLASS GEWINDE
12	ABZUGSHAUBE
13	ZUBEHÖRTEILENVERBINDUNG
27	KÜHLLUFTAustrITT
30	ABGASKAMIN

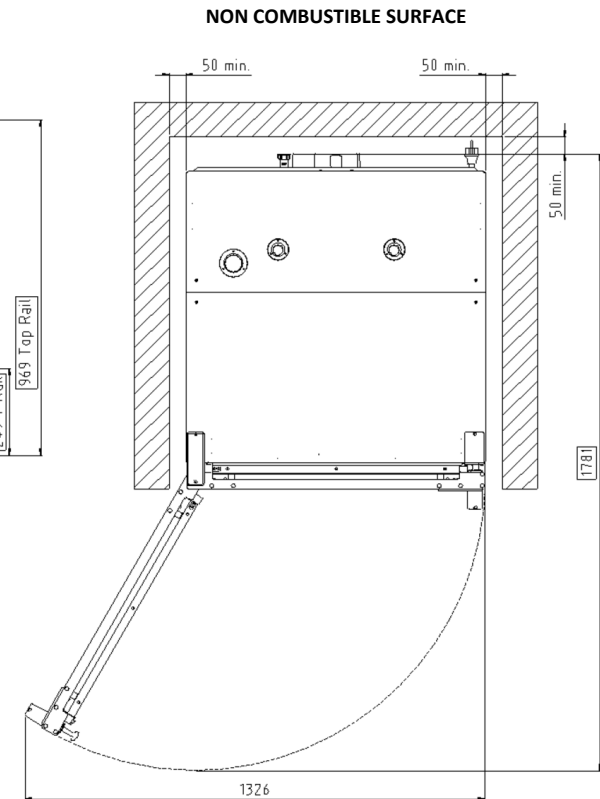
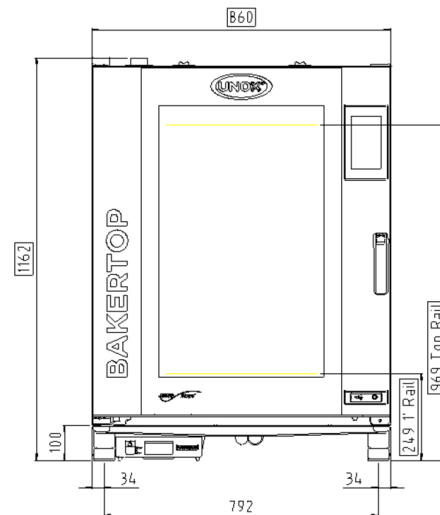
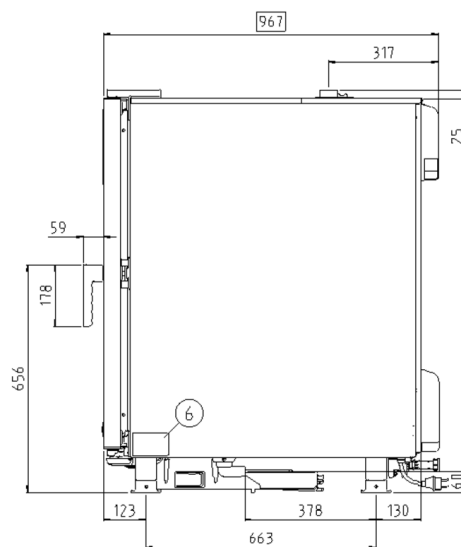
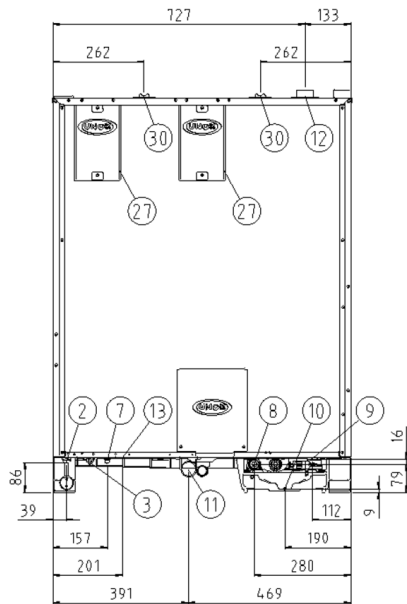

MOD:XEBC-10EU-GPRM

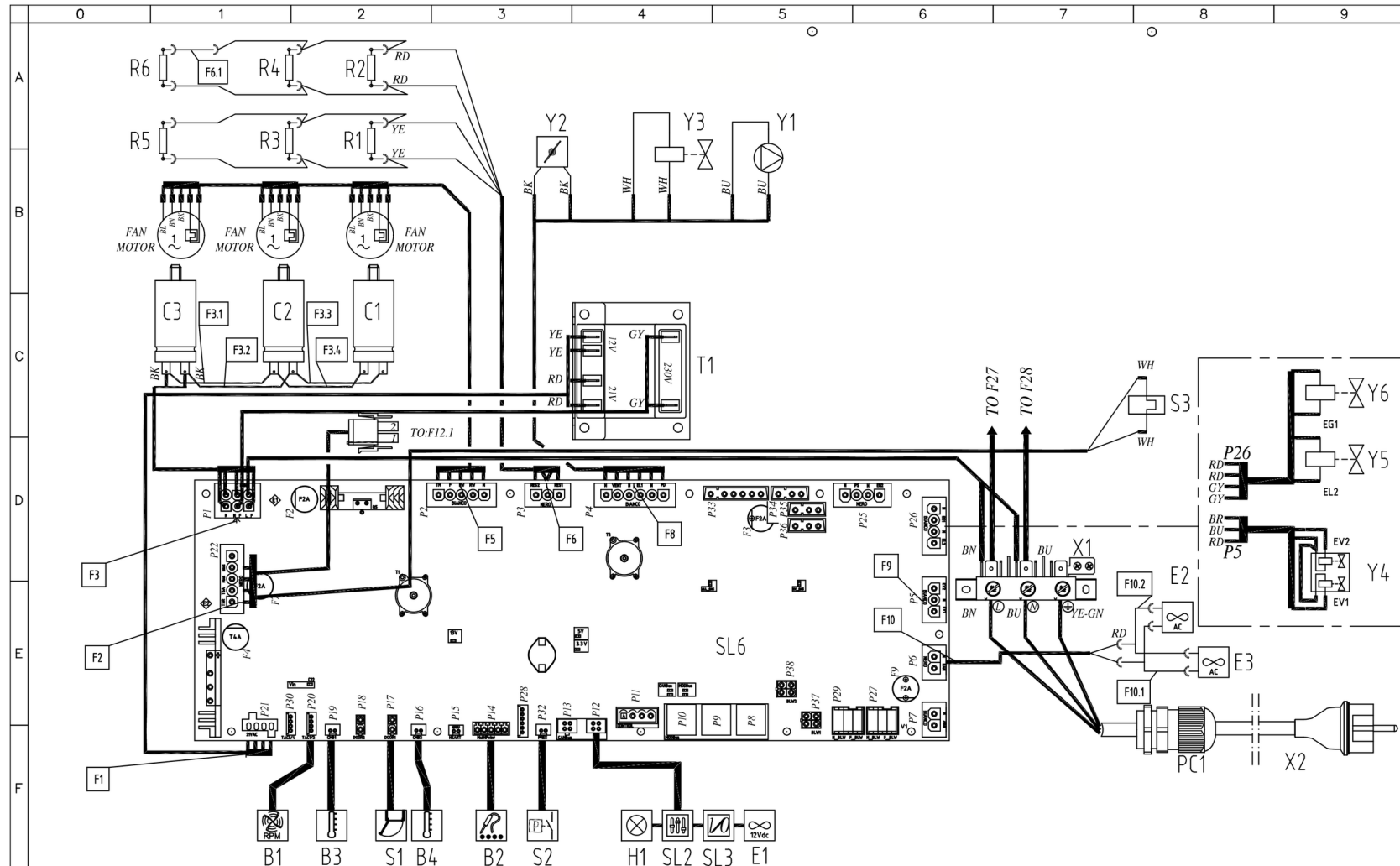

MOD:XEBC-10EU-GPRM

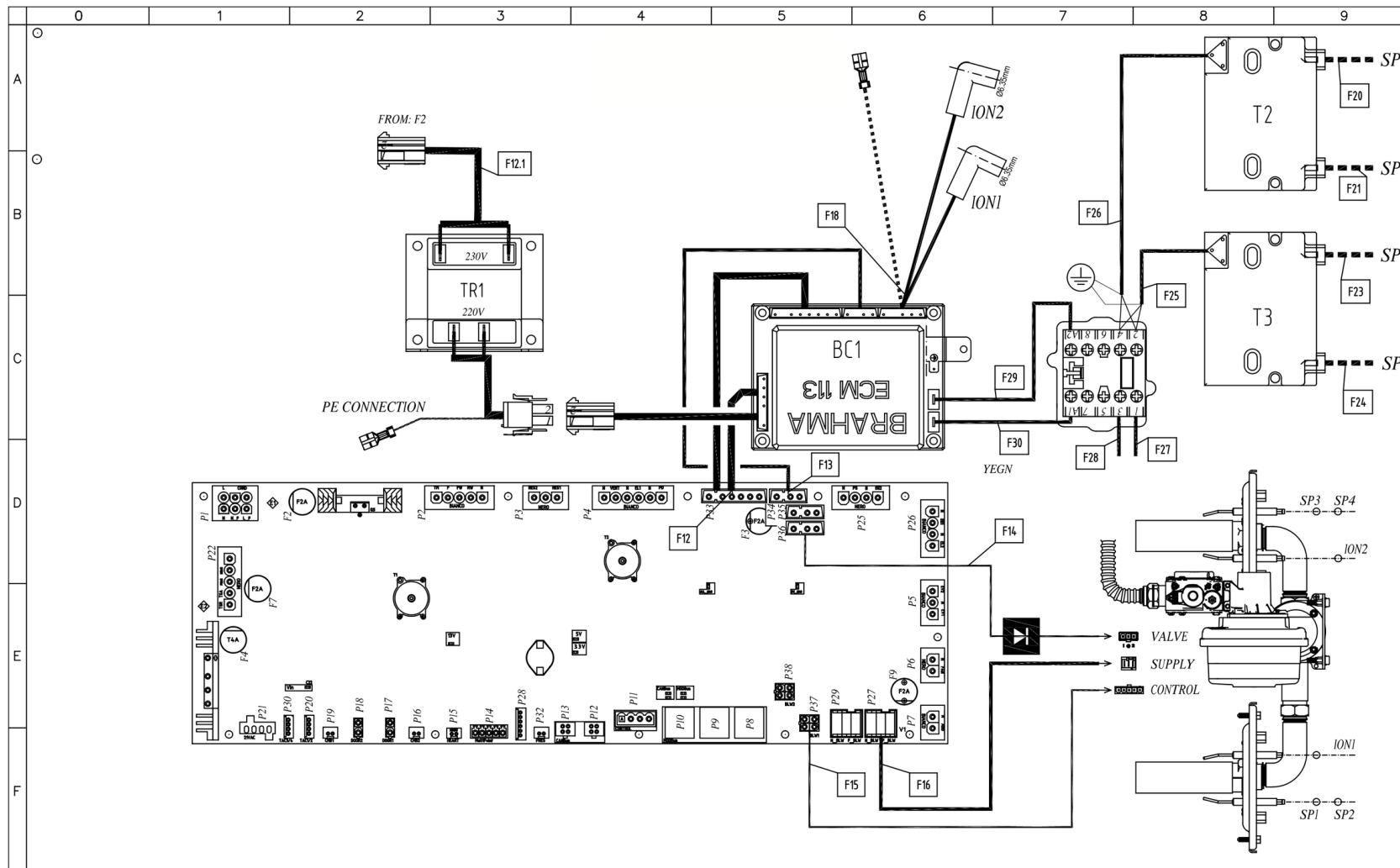

MOD:XEBC-10EU-GPRM



	0	1	2	3	4	5	6	7	8	9																																																																																																																																																																															
A																																																																																																																																																																																									
B	<table border="1"> <thead> <tr> <th>Sigle</th> <th>ITALIANO</th> <th>ENGLISH</th> <th>FRANCAIS</th> <th>ESPAÑOL</th> <th>DEUTSCH</th> </tr> </thead> <tbody> <tr> <td>B1</td> <td>SENSORE VELOCITA MOTORE</td> <td>MOTOR SPEED SENSOR</td> <td>CAPTEUR DE VITESSE MOTEUR</td> <td>SENSOR DE VELOCIDAD MOTOR</td> <td>GESCHWINDIGKEITSSENSOR</td> </tr> <tr> <td>B2</td> <td>SONDA AL CUORE</td> <td>CORE PROBE</td> <td>SONDE A COEUR</td> <td>SONDA CORAZON</td> <td>KERNTEMPERATURFUHLER</td> </tr> <tr> <td>B3,B4</td> <td>SONDA CAMERA</td> <td>TEMPERATURE PROBE</td> <td>SONDE DE CHAMBRE</td> <td>SONDA CAMARA</td> <td>GARRAUMTEMPERATURFUHLER</td> </tr> <tr> <td>H1</td> <td>LUCE CAMERA</td> <td>OVEN LIGHT</td> <td>ECLAIRAGE DE CHAMBRE</td> <td>LUZ CAMARA</td> <td>BELEUCHTUNG</td> </tr> <tr> <td>R1,R2,R3,R4,R5,R6</td> <td>RESISTENZA DI MODULAZIONE VENTILATORE</td> <td>MOTOR MODULATION RESISTANCE</td> <td>RESISTANCE DE MODULATION VENTILATEUR</td> <td>RESISTENCIA MODULACION VELOCIDAD</td> <td>WIDERSTAND LOW FAN</td> </tr> <tr> <td>S1</td> <td>MICRO INTERRUTTORE PORTA</td> <td>DOOR MICROSWITCH</td> <td>MICROINTERRUPTEUR DE PORTE</td> <td>MICROINTERRUPTOR PUERTA</td> <td>TURKONTAKTSCHALTER</td> </tr> <tr> <td>S2</td> <td>PRESSOSTATO</td> <td>PRESSURE SWITCH</td> <td>PRESSOSTAT</td> <td>PRESOSTATO</td> <td>DRUCKSCHALTER</td> </tr> <tr> <td>S3</td> <td>TERMOSTATO SICUREZZA</td> <td>SAFETY THERMOSTAT</td> <td>THERMOSTAT DE SECURITE</td> <td>TERMOSTATO DE SEGURIDAD</td> <td>SICHERHEITS THERMOSTAT</td> </tr> <tr> <td>SL2</td> <td>SCHEDA CONTROLLO</td> <td>CONTROL BOARD</td> <td>CARTE DE CONTROLE</td> <td>TARJETA DE CONTROL</td> <td>KONTROLL PLATINE</td> </tr> <tr> <td>SL3</td> <td>SCHEDA I/O - USB</td> <td>USB - I/O BOARD</td> <td>USB - CARTE I/O</td> <td>USB - TARJETA I/O</td> <td>USB - I/O PLATINE</td> </tr> <tr> <td>Y1</td> <td>POMPA</td> <td>PUMP</td> <td>POMPE</td> <td>BOMBA</td> <td>PUMPE</td> </tr> <tr> <td>Y2</td> <td>DRY MAXY</td> <td>DRY MAXY</td> <td>DRY MAXY</td> <td>DRY MAXY</td> <td>DRY MAXY</td> </tr> <tr> <td>Y3,Y5,Y6</td> <td>ELETTROVALVOLA ACQUA</td> <td>WATER SOLENOID VALVE</td> <td>ELECTROVANNE EAU</td> <td>ELECTROVALVULA</td> <td>ELEKTROVENTIL</td> </tr> <tr> <td>Y4</td> <td>ELETTROVALVOLA ACQUA 3 STADI</td> <td>WATER SOLENOID VALVE 3STAGE</td> <td>ELECTROVANNE EAU 3 ETAPES</td> <td>ELECTROVALVULA 3 ETAPAS</td> <td>ELEKTROVENTIL 3 STUFEN</td> </tr> <tr> <td>BC1</td> <td>CONTROLLO FIAMMA</td> <td>FLAME CONTROL DEVICE</td> <td>FLAMME RELEVATRICE</td> <td>CONTROL LLAMA</td> <td>FLAMMESTEUERUNG</td> </tr> <tr> <td>C1,C2,C3</td> <td>CONDENSATORE</td> <td>MOTOR CAPACITOR</td> <td>CONDENSATEUR</td> <td>CONDENSADOR</td> <td>KONDENSATOR</td> </tr> <tr> <td>E1</td> <td>VENTOLA RAFFREDDAMENTO 12V</td> <td>COOLING FAN 12V</td> <td>TURBINE DE REFRROIDISSEMENT 12V</td> <td>TURBINA DE REFRIGERACION 12V</td> <td>LÜFTER 12V</td> </tr> <tr> <td>E2,E3</td> <td>VENTOLA RAFFREDDAMENTO 230V</td> <td>COOLING FAN 230V</td> <td>TURBINE DE REFRROIDISSEMENT 230V</td> <td>TURBINA DE REFRIGERACION 230V</td> <td>LÜFTER 230V</td> </tr> <tr> <td>K1</td> <td>TELERUTTORE</td> <td>CONTACTOR</td> <td>TELERUPTEUR</td> <td>TELERRUPTOR</td> <td>RELAIS</td> </tr> <tr> <td>PC1</td> <td>PRESSACAVO PG 13,5</td> <td>CABLE GLAND / CORDGRIP PG13,5</td> <td>PRESSE ETOUPE PG13,5</td> <td>PASACABLES PG13,5</td> <td>Drüse PG13,5</td> </tr> <tr> <td>PC2</td> <td>DADO PRESSACAVO PG13,5</td> <td>LOCKNUT PG13,5</td> <td>E CROU PRESSE-ETOUBE PG13,5</td> <td>NUT PASACABLES PG13,5</td> <td>ÜBERWURFMUTTER PG13,5</td> </tr> <tr> <td>SL4</td> <td>BRIDGE ETHERNET</td> <td>BRIDGE ETHERNET</td> <td>BRIDGE ETHERNET</td> <td>BRIDGE ETHERNET</td> <td>BRIDGE ETHERNET</td> </tr> <tr> <td>SL6</td> <td>SCHEDA POTENZA</td> <td>POWER CARD</td> <td>CARTE DE PUISSANCE</td> <td>TARJETA POTENCIA</td> <td>POWERPLATINE</td> </tr> <tr> <td>T1</td> <td>TRASFORMATORE</td> <td>TRANSFORMER</td> <td>TRANSFORMATEUR</td> <td>TRANSFORMADOR</td> <td>TRANSFORMATOR</td> </tr> <tr> <td>T2,T3</td> <td>TRASFORMATORE D'ACCENSIONE</td> <td>IGNITION TRANSFORMER</td> <td>TRANSFORMATEUR D'ALLUMAGE</td> <td>TRANSFORMADOR D'INGICION</td> <td>ZÜNDTRASFORMATOR</td> </tr> <tr> <td>TR1</td> <td>TRASFORMATORE</td> <td>TRANSFORMER</td> <td>TRANSFORMATEUR</td> <td>TRANSFORMADOR</td> <td>TRASFORMATORE</td> </tr> <tr> <td>X1</td> <td>MORSETTIERA</td> <td>TERMINAL BLOCK</td> <td>BORNIER</td> <td>CONECTOR</td> <td>KLEMMLEISTE</td> </tr> <tr> <td>X2</td> <td>CAVO ALIMENTAZIONE + SCHUKO</td> <td>POWER CORD + SCHUKO</td> <td>EPINIERE ET SCHUKO</td> <td>CABLE Y ENCHUFE SCHUKO</td> <td>KABEL UND SCHUKO-STECKER</td> </tr> </tbody> </table>	Sigle	ITALIANO	ENGLISH	FRANCAIS	ESPAÑOL	DEUTSCH	B1	SENSORE VELOCITA MOTORE	MOTOR SPEED SENSOR	CAPTEUR DE VITESSE MOTEUR	SENSOR DE VELOCIDAD MOTOR	GESCHWINDIGKEITSSENSOR	B2	SONDA AL CUORE	CORE PROBE	SONDE A COEUR	SONDA CORAZON	KERNTEMPERATURFUHLER	B3,B4	SONDA CAMERA	TEMPERATURE PROBE	SONDE DE CHAMBRE	SONDA CAMARA	GARRAUMTEMPERATURFUHLER	H1	LUCE CAMERA	OVEN LIGHT	ECLAIRAGE DE CHAMBRE	LUZ CAMARA	BELEUCHTUNG	R1,R2,R3,R4,R5,R6	RESISTENZA DI MODULAZIONE VENTILATORE	MOTOR MODULATION RESISTANCE	RESISTANCE DE MODULATION VENTILATEUR	RESISTENCIA MODULACION VELOCIDAD	WIDERSTAND LOW FAN	S1	MICRO INTERRUTTORE PORTA	DOOR MICROSWITCH	MICROINTERRUPTEUR DE PORTE	MICROINTERRUPTOR PUERTA	TURKONTAKTSCHALTER	S2	PRESSOSTATO	PRESSURE SWITCH	PRESSOSTAT	PRESOSTATO	DRUCKSCHALTER	S3	TERMOSTATO SICUREZZA	SAFETY THERMOSTAT	THERMOSTAT DE SECURITE	TERMOSTATO DE SEGURIDAD	SICHERHEITS THERMOSTAT	SL2	SCHEDA CONTROLLO	CONTROL BOARD	CARTE DE CONTROLE	TARJETA DE CONTROL	KONTROLL PLATINE	SL3	SCHEDA I/O - USB	USB - I/O BOARD	USB - CARTE I/O	USB - TARJETA I/O	USB - I/O PLATINE	Y1	POMPA	PUMP	POMPE	BOMBA	PUMPE	Y2	DRY MAXY	DRY MAXY	DRY MAXY	DRY MAXY	DRY MAXY	Y3,Y5,Y6	ELETTROVALVOLA ACQUA	WATER SOLENOID VALVE	ELECTROVANNE EAU	ELECTROVALVULA	ELEKTROVENTIL	Y4	ELETTROVALVOLA ACQUA 3 STADI	WATER SOLENOID VALVE 3STAGE	ELECTROVANNE EAU 3 ETAPES	ELECTROVALVULA 3 ETAPAS	ELEKTROVENTIL 3 STUFEN	BC1	CONTROLLO FIAMMA	FLAME CONTROL DEVICE	FLAMME RELEVATRICE	CONTROL LLAMA	FLAMMESTEUERUNG	C1,C2,C3	CONDENSATORE	MOTOR CAPACITOR	CONDENSATEUR	CONDENSADOR	KONDENSATOR	E1	VENTOLA RAFFREDDAMENTO 12V	COOLING FAN 12V	TURBINE DE REFRROIDISSEMENT 12V	TURBINA DE REFRIGERACION 12V	LÜFTER 12V	E2,E3	VENTOLA RAFFREDDAMENTO 230V	COOLING FAN 230V	TURBINE DE REFRROIDISSEMENT 230V	TURBINA DE REFRIGERACION 230V	LÜFTER 230V	K1	TELERUTTORE	CONTACTOR	TELERUPTEUR	TELERRUPTOR	RELAIS	PC1	PRESSACAVO PG 13,5	CABLE GLAND / CORDGRIP PG13,5	PRESSE ETOUPE PG13,5	PASACABLES PG13,5	Drüse PG13,5	PC2	DADO PRESSACAVO PG13,5	LOCKNUT PG13,5	E CROU PRESSE-ETOUBE PG13,5	NUT PASACABLES PG13,5	ÜBERWURFMUTTER PG13,5	SL4	BRIDGE ETHERNET	BRIDGE ETHERNET	BRIDGE ETHERNET	BRIDGE ETHERNET	BRIDGE ETHERNET	SL6	SCHEDA POTENZA	POWER CARD	CARTE DE PUISSANCE	TARJETA POTENCIA	POWERPLATINE	T1	TRASFORMATORE	TRANSFORMER	TRANSFORMATEUR	TRANSFORMADOR	TRANSFORMATOR	T2,T3	TRASFORMATORE D'ACCENSIONE	IGNITION TRANSFORMER	TRANSFORMATEUR D'ALLUMAGE	TRANSFORMADOR D'INGICION	ZÜNDTRASFORMATOR	TR1	TRASFORMATORE	TRANSFORMER	TRANSFORMATEUR	TRANSFORMADOR	TRASFORMATORE	X1	MORSETTIERA	TERMINAL BLOCK	BORNIER	CONECTOR	KLEMMLEISTE	X2	CAVO ALIMENTAZIONE + SCHUKO	POWER CORD + SCHUKO	EPINIERE ET SCHUKO	CABLE Y ENCHUFE SCHUKO	KABEL UND SCHUKO-STECKER										
Sigle	ITALIANO	ENGLISH	FRANCAIS	ESPAÑOL	DEUTSCH																																																																																																																																																																																				
B1	SENSORE VELOCITA MOTORE	MOTOR SPEED SENSOR	CAPTEUR DE VITESSE MOTEUR	SENSOR DE VELOCIDAD MOTOR	GESCHWINDIGKEITSSENSOR																																																																																																																																																																																				
B2	SONDA AL CUORE	CORE PROBE	SONDE A COEUR	SONDA CORAZON	KERNTEMPERATURFUHLER																																																																																																																																																																																				
B3,B4	SONDA CAMERA	TEMPERATURE PROBE	SONDE DE CHAMBRE	SONDA CAMARA	GARRAUMTEMPERATURFUHLER																																																																																																																																																																																				
H1	LUCE CAMERA	OVEN LIGHT	ECLAIRAGE DE CHAMBRE	LUZ CAMARA	BELEUCHTUNG																																																																																																																																																																																				
R1,R2,R3,R4,R5,R6	RESISTENZA DI MODULAZIONE VENTILATORE	MOTOR MODULATION RESISTANCE	RESISTANCE DE MODULATION VENTILATEUR	RESISTENCIA MODULACION VELOCIDAD	WIDERSTAND LOW FAN																																																																																																																																																																																				
S1	MICRO INTERRUTTORE PORTA	DOOR MICROSWITCH	MICROINTERRUPTEUR DE PORTE	MICROINTERRUPTOR PUERTA	TURKONTAKTSCHALTER																																																																																																																																																																																				
S2	PRESSOSTATO	PRESSURE SWITCH	PRESSOSTAT	PRESOSTATO	DRUCKSCHALTER																																																																																																																																																																																				
S3	TERMOSTATO SICUREZZA	SAFETY THERMOSTAT	THERMOSTAT DE SECURITE	TERMOSTATO DE SEGURIDAD	SICHERHEITS THERMOSTAT																																																																																																																																																																																				
SL2	SCHEDA CONTROLLO	CONTROL BOARD	CARTE DE CONTROLE	TARJETA DE CONTROL	KONTROLL PLATINE																																																																																																																																																																																				
SL3	SCHEDA I/O - USB	USB - I/O BOARD	USB - CARTE I/O	USB - TARJETA I/O	USB - I/O PLATINE																																																																																																																																																																																				
Y1	POMPA	PUMP	POMPE	BOMBA	PUMPE																																																																																																																																																																																				
Y2	DRY MAXY	DRY MAXY	DRY MAXY	DRY MAXY	DRY MAXY																																																																																																																																																																																				
Y3,Y5,Y6	ELETTROVALVOLA ACQUA	WATER SOLENOID VALVE	ELECTROVANNE EAU	ELECTROVALVULA	ELEKTROVENTIL																																																																																																																																																																																				
Y4	ELETTROVALVOLA ACQUA 3 STADI	WATER SOLENOID VALVE 3STAGE	ELECTROVANNE EAU 3 ETAPES	ELECTROVALVULA 3 ETAPAS	ELEKTROVENTIL 3 STUFEN																																																																																																																																																																																				
BC1	CONTROLLO FIAMMA	FLAME CONTROL DEVICE	FLAMME RELEVATRICE	CONTROL LLAMA	FLAMMESTEUERUNG																																																																																																																																																																																				
C1,C2,C3	CONDENSATORE	MOTOR CAPACITOR	CONDENSATEUR	CONDENSADOR	KONDENSATOR																																																																																																																																																																																				
E1	VENTOLA RAFFREDDAMENTO 12V	COOLING FAN 12V	TURBINE DE REFRROIDISSEMENT 12V	TURBINA DE REFRIGERACION 12V	LÜFTER 12V																																																																																																																																																																																				
E2,E3	VENTOLA RAFFREDDAMENTO 230V	COOLING FAN 230V	TURBINE DE REFRROIDISSEMENT 230V	TURBINA DE REFRIGERACION 230V	LÜFTER 230V																																																																																																																																																																																				
K1	TELERUTTORE	CONTACTOR	TELERUPTEUR	TELERRUPTOR	RELAIS																																																																																																																																																																																				
PC1	PRESSACAVO PG 13,5	CABLE GLAND / CORDGRIP PG13,5	PRESSE ETOUPE PG13,5	PASACABLES PG13,5	Drüse PG13,5																																																																																																																																																																																				
PC2	DADO PRESSACAVO PG13,5	LOCKNUT PG13,5	E CROU PRESSE-ETOUBE PG13,5	NUT PASACABLES PG13,5	ÜBERWURFMUTTER PG13,5																																																																																																																																																																																				
SL4	BRIDGE ETHERNET	BRIDGE ETHERNET	BRIDGE ETHERNET	BRIDGE ETHERNET	BRIDGE ETHERNET																																																																																																																																																																																				
SL6	SCHEDA POTENZA	POWER CARD	CARTE DE PUISSANCE	TARJETA POTENCIA	POWERPLATINE																																																																																																																																																																																				
T1	TRASFORMATORE	TRANSFORMER	TRANSFORMATEUR	TRANSFORMADOR	TRANSFORMATOR																																																																																																																																																																																				
T2,T3	TRASFORMATORE D'ACCENSIONE	IGNITION TRANSFORMER	TRANSFORMATEUR D'ALLUMAGE	TRANSFORMADOR D'INGICION	ZÜNDTRASFORMATOR																																																																																																																																																																																				
TR1	TRASFORMATORE	TRANSFORMER	TRANSFORMATEUR	TRANSFORMADOR	TRASFORMATORE																																																																																																																																																																																				
X1	MORSETTIERA	TERMINAL BLOCK	BORNIER	CONECTOR	KLEMMLEISTE																																																																																																																																																																																				
X2	CAVO ALIMENTAZIONE + SCHUKO	POWER CORD + SCHUKO	EPINIERE ET SCHUKO	CABLE Y ENCHUFE SCHUKO	KABEL UND SCHUKO-STECKER																																																																																																																																																																																				
C																																																																																																																																																																																									
D																																																																																																																																																																																									
E																																																																																																																																																																																									
F																																																																																																																																																																																									

MOD:XEBC-10EU-GPRM



TAB100026H										Throttle [turns from closed position]	Throttle [A turns from G20 setting]	Gas fumes test 1 (MAX)		Gas fumes test 2 (MIN)		
Installation type: A3- Free Single unit B13- Unit with draught diverter B23- Single or Stacked units under hood												CO2 [%v/v]	CO [ppm]	CO2 [%v/v]	CO [ppm]	
Oven Model	Tray type	Gas type	Nominal GAS power [kW]	Nominal GAS power [MJ/h]	Inlet pressure [mbar]	Ø GAS Valve orifice [mm]										
XEVC-0511-GPX - XEVC-0511-GPXM	GN1/1	G110	12,5	45	5 - 40 mbar	-	14	4,5	4,50 ≤ CO2 ≤ 5,00	<30	4,50 ≤ CO2 ≤ 5,00	<30	8,00 ≤ CO2 ≤ 11,30			
		G20	15	54	5 - 40 mbar	-	9,5	-	9,10 ≤ CO2 ≤ 9,50		8,00 ≤ CO2 ≤ 11,30					
		G25	15	54	5 - 40 mbar	-	9,25	-0,25	9,00 ≤ CO2 ≤ 9,40		8,00 ≤ CO2 ≤ 11,30					
		G25.1	15	54	5 - 40 mbar	-	9,5	0	9,60 ≤ CO2 ≤ 10,00		8,50 ≤ CO2 ≤ 12,00					
		G25.3	15	54	5 - 40 mbar	-	9,25	-0,25	9,30 ≤ CO2 ≤ 9,70		8,00 ≤ CO2 ≤ 11,30					
		G30	15	54	5 - 40 mbar	5,5	8,75	-0,75	11,60 ≤ CO2 ≤ 12,00		8,50 ≤ CO2 ≤ 12,50					
XEVC-0711-GPX - XEVC-0711-GPXM	GN1/1	G110	16	57,6	5 - 40 mbar	-	14	4,5	4,50 ≤ CO2 ≤ 5,00	<30	4,50 ≤ CO2 ≤ 5,00	<30	8,00 ≤ CO2 ≤ 11,30			
		G20	19	68,4	5 - 40 mbar	-	9,5	-	9,30 ≤ CO2 ≤ 9,70		8,00 ≤ CO2 ≤ 11,30					
		G25	19	68,4	5 - 40 mbar	-	9,25	-0,25	9,30 ≤ CO2 ≤ 9,50		8,00 ≤ CO2 ≤ 11,30					
		G25.1	19	68,4	5 - 40 mbar	-	9,25	-0,25	9,80 ≤ CO2 ≤ 10,20		8,50 ≤ CO2 ≤ 12,00					
		G25.3	19	68,4	5 - 40 mbar	-	9,25	-0,25	9,60 ≤ CO2 ≤ 10,00		8,00 ≤ CO2 ≤ 11,30					
		G30	19	68,4	5 - 40 mbar	5,5	8,75	-0,75	11,40 ≤ CO2 ≤ 11,80		8,50 ≤ CO2 ≤ 12,50					
XEVC-1011-GPX - XEVC-1011-GPXM	GN1/1	G110	17	61,2	5 - 40 mbar	-	14	4,25	4,50 ≤ CO2 ≤ 5,00	<30	4,50 ≤ CO2 ≤ 5,00	<30	8,00 ≤ CO2 ≤ 11,30			
		G20	22	79,2	5 - 40 mbar	-	9,75	-	9,20 ≤ CO2 ≤ 9,60		8,00 ≤ CO2 ≤ 11,30					
		G25	22	79,2	5 - 40 mbar	-	9,5	-0,25	9,20 ≤ CO2 ≤ 9,60		8,00 ≤ CO2 ≤ 11,30					
		G25.1	22	79,2	5 - 40 mbar	-	9,25	-0,5	10,20 ≤ CO2 ≤ 10,60		8,50 ≤ CO2 ≤ 12,00					
		G25.3	22	79,2	5 - 40 mbar	-	9,25	-0,5	9,50 ≤ CO2 ≤ 9,90		8,00 ≤ CO2 ≤ 11,30					
		G30	22	79,2	5 - 40 mbar	5,5	8,75	-1	11,50 ≤ CO2 ≤ 11,90		8,50 ≤ CO2 ≤ 12,50					
XEVC-2011-GPX	GN1/1	G110	26	93,6	5 - 40 mbar	-	14	4,25	4,50 ≤ CO2 ≤ 5,00	<30	4,50 ≤ CO2 ≤ 5,00	<30	8,00 ≤ CO2 ≤ 11,30			
		G20	35	126	5 - 40 mbar	-	9,75	-	9,50 ≤ CO2 ≤ 9,90		8,00 ≤ CO2 ≤ 11,30					
		G25	35	126	5 - 40 mbar	-	9,5	-0,25	9,40 ≤ CO2 ≤ 9,80		8,00 ≤ CO2 ≤ 11,30					
		G25.1	35	126	5 - 40 mbar	-	9,5	-0,25	10,10 ≤ CO2 ≤ 10,50		8,50 ≤ CO2 ≤ 12,00					
		G25.3	35	126	5 - 40 mbar	-	9,75	0	9,40 ≤ CO2 ≤ 9,80		8,00 ≤ CO2 ≤ 11,30					
		G30	35	126	5 - 40 mbar	5,5	8,75	-1	11,50 ≤ CO2 ≤ 11,90		8,50 ≤ CO2 ≤ 12,50					
XEVC-0621-GPX - XEVC-0621-GPXM	GN2/1	G110	16	57,6	5 - 40 mbar	-	14	4,5	4,50 ≤ CO2 ≤ 5,00	<30	4,50 ≤ CO2 ≤ 5,00	<30	8,00 ≤ CO2 ≤ 11,30			
		G20	24	86,4	5 - 40 mbar	-	9,5	-	9,20 ≤ CO2 ≤ 9,60		8,00 ≤ CO2 ≤ 11,30					
		G25	23	82,8	5 - 40 mbar	-	9,5	0	9,20 ≤ CO2 ≤ 9,60		8,00 ≤ CO2 ≤ 11,30					
		G25.1	22	79,2	5 - 40 mbar	-	9,5	0	10,20 ≤ CO2 ≤ 10,60		8,50 ≤ CO2 ≤ 12,00					
		G25.3	22	79,2	5 - 40 mbar	-	9,5	0	9,20 ≤ CO2 ≤ 9,60		8,00 ≤ CO2 ≤ 11,30					
		G30	24	86,4	5 - 40 mbar	5,5	8,75	-0,75	11,40 ≤ CO2 ≤ 11,80		8,50 ≤ CO2 ≤ 12,50					
G31	24	86,4	5 - 40 mbar	5,5	9	-0,5	11,20 ≤ CO2 ≤ 11,60	8,50 ≤ CO2 ≤ 12,50								

For Australia / New Zealand - EUROPEAN GASES and CORRESPONDING AUSTRALIAN GASES

EUROPEAN GASES and CORRESPONDING AUSTRALIAN GASES		
EUROPEAN	AUSTRALIAN	MINIMUM PRESSURE AT THE GAS OVENS INLET (kPa)
G20	NATURAL GAS (N GAS)	1.13
G30	BUTANE (Y GAS)	2.75
G31	PROPANE (X GAS)	2.75

MOD:XEBC-10EU-GPRM



TAB100026H										Throttle [turns from closed position]	Throttle [Δ turns from G20 setting]	Gas fumes test 1 (MAX)		Gas fumes test 2 (MIN)	
Oven Model	Tray type	Gas type	Nominal GAS power [kW]	Nominal GAS power [MJ/h]	Inlet pressure [mbar]	Ø GAS Valve orifice [mm]	CO2 [% v/v]	CO [ppm]	CO2 [% v/v]			CO [ppm]			
Installation type: A3- Free Single unit B13- Unit with draught diverter B23- Single or Stacked units under hood															
XEVC-1021-GPX XEVC-1021-GPXM	GN2/1	G110	23	82,8	5 - 40 mbar	-	14	4,25	4,50 ≤ CO2 ≤ 5,00	4,50 ≤ CO2 ≤ 5,00					
		G20	35	126	5 - 40 mbar	-	9,75	-	9,20 ≤ CO2 ≤ 9,60	8,00 ≤ CO2 ≤ 11,30					
		G25	31,5	113,4	5 - 40 mbar	-	9,5	-0,25	9,20 ≤ CO2 ≤ 9,60	8,00 ≤ CO2 ≤ 11,30					
		G25.1	31,5	113,4	5 - 40 mbar	-	9,5	-0,25	10,10 ≤ CO2 ≤ 10,50	8,50 ≤ CO2 ≤ 12,00	<30	<30			
		G25.3	31,5	113,4	5 - 40 mbar	-	9,25	-0,5	9,60 ≤ CO2 ≤ 10,00	8,00 ≤ CO2 ≤ 11,30					
		G30	35	126	5 - 40 mbar	5,5	8,75	-1	11,40 ≤ CO2 ≤ 11,80	8,50 ≤ CO2 ≤ 12,50					
XEVC-2021-GPX	GN2/1	G110	38	136,8	5 - 40 mbar	-	14	4	4,20 ≤ CO2 ≤ 5,00	4,20 ≤ CO2 ≤ 5,00					
		G20	69	248,4	5 - 40 mbar	-	10	-	9,30 ≤ CO2 ≤ 9,70	8,00 ≤ CO2 ≤ 11,30					
		G25	66	237,6	5 - 40 mbar	-	9,25	-0,75	9,30 ≤ CO2 ≤ 9,70	8,00 ≤ CO2 ≤ 11,30					
		G25.1	63	226,8	5 - 40 mbar	-	9,5	-0,5	10,20 ≤ CO2 ≤ 10,60	8,50 ≤ CO2 ≤ 12,00	<30	<30			
		G25.3	65	234	5 - 40 mbar	-	9,25	-0,75	9,70 ≤ CO2 ≤ 10,10	8,00 ≤ CO2 ≤ 11,30					
		G30	70	252	5 - 40 mbar	5,5	8,75	-1,25	11,50 ≤ CO2 ≤ 11,90	8,50 ≤ CO2 ≤ 12,50					
XEBC-06EU-GPX XEBC-06EU-GPXM	600x400	G110	16	57,6	5 - 40 mbar	-	14	4,5	4,50 ≤ CO2 ≤ 5,00	4,50 ≤ CO2 ≤ 5,00					
		G20	19	68,4	5 - 40 mbar	-	9,5	-	9,30 ≤ CO2 ≤ 9,70	8,00 ≤ CO2 ≤ 11,30					
		G25	19	68,4	5 - 40 mbar	-	9,25	-0,25	9,30 ≤ CO2 ≤ 9,50	8,00 ≤ CO2 ≤ 11,30					
		G25.1	19	68,4	5 - 40 mbar	-	9,25	-0,25	9,80 ≤ CO2 ≤ 10,20	8,50 ≤ CO2 ≤ 12,00	<30	<30			
		G25.3	19	68,4	5 - 40 mbar	-	9,25	-0,25	9,60 ≤ CO2 ≤ 10,00	8,00 ≤ CO2 ≤ 11,30					
		G30	19	68,4	5 - 40 mbar	5,5	8,75	-0,75	11,40 ≤ CO2 ≤ 11,80	8,50 ≤ CO2 ≤ 12,50					
XEBC-10EU-GPX XEBC-10EU-GPXM	600x400	G110	20	72	5 - 40 mbar	-	14	4,25	4,50 ≤ CO2 ≤ 5,00	4,50 ≤ CO2 ≤ 5,00					
		G20	25	90	5 - 40 mbar	-	9,75	-	9,20 ≤ CO2 ≤ 9,60	8,00 ≤ CO2 ≤ 11,30					
		G25	24	86,4	5 - 40 mbar	-	9,5	-0,25	9,30 ≤ CO2 ≤ 9,70	8,00 ≤ CO2 ≤ 11,30					
		G25.1	23	82,8	5 - 40 mbar	-	9,25	-0,5	10,20 ≤ CO2 ≤ 10,60	8,50 ≤ CO2 ≤ 12,00	<30	<30			
		G25.3	21	75,6	5 - 40 mbar	-	9,25	-0,5	9,30 ≤ CO2 ≤ 9,70	8,00 ≤ CO2 ≤ 11,30					
		G30	25	90	5 - 40 mbar	5,5	9	-0,75	11,50 ≤ CO2 ≤ 11,90	8,50 ≤ CO2 ≤ 12,50					
XEBC-16EU-GPX	600x400	G110	26	93,6	5 - 40 mbar	-	14	4,25	4,50 ≤ CO2 ≤ 5,00	4,50 ≤ CO2 ≤ 5,00					
		G20	35	126	5 - 40 mbar	-	9,75	-	9,50 ≤ CO2 ≤ 9,90	8,00 ≤ CO2 ≤ 11,30					
		G25	35	126	5 - 40 mbar	-	9,5	-0,25	9,40 ≤ CO2 ≤ 9,80	8,00 ≤ CO2 ≤ 11,30					
		G25.1	35	126	5 - 40 mbar	-	9,5	-0,25	10,10 ≤ CO2 ≤ 10,50	8,50 ≤ CO2 ≤ 12,00	<30	<30			
		G25.3	35	126	5 - 40 mbar	-	9,75	0	9,40 ≤ CO2 ≤ 9,80	8,00 ≤ CO2 ≤ 11,30					
		G30	35	126	5 - 40 mbar	5,5	8,75	-1	11,50 ≤ CO2 ≤ 11,90	8,50 ≤ CO2 ≤ 12,50					
G31	35	126	5 - 40 mbar	5,5	9	-0,75	11,40 ≤ CO2 ≤ 11,80	8,50 ≤ CO2 ≤ 12,50							

For Australia / New Zealand - EUROPEAN GASES and CORRESPONDING AUSTRALIAN GASES

EUROPEAN GASES and CORRESPONDING AUSTRALIAN GASES			
EUROPEAN	AUSTRALIAN	MINIMUM PRESSURE AT THE GAS OVENS INLET (kPa)	
G20	NATURAL GAS (N GAS)	1.13	
G30	BUTANE (Y GAS)	2.75	
G31	PROPANE (X GAS)	2.75	